

A large industrial IBC blending module is shown in a factory setting. The machine is white and has a hopper at the bottom. It is mounted on a pallet. The background is a blue-tinted image of the factory floor.

**MATCON**<sup>®</sup>

POWDERS, HANDLED.

# IBC BLENDING MODULE

---

ELIMINATE CLEANING DOWNTIME.  
EVERY TIME.

Mix any recipe, any time, through  
fast, efficient, agile blending with  
Matcon IBC blending systems.

---

[www.matconibc.com](http://www.matconibc.com)



POWDERS, HANDLED.

# The Industrial Mixer for fast, efficient, agile blending

Achieve a flexible and efficient mixing process.

Because the IBC is the blending vessel, there is no downtime for cleaning and no risk of cross-contamination. All filling and emptying takes place independent of the blender.

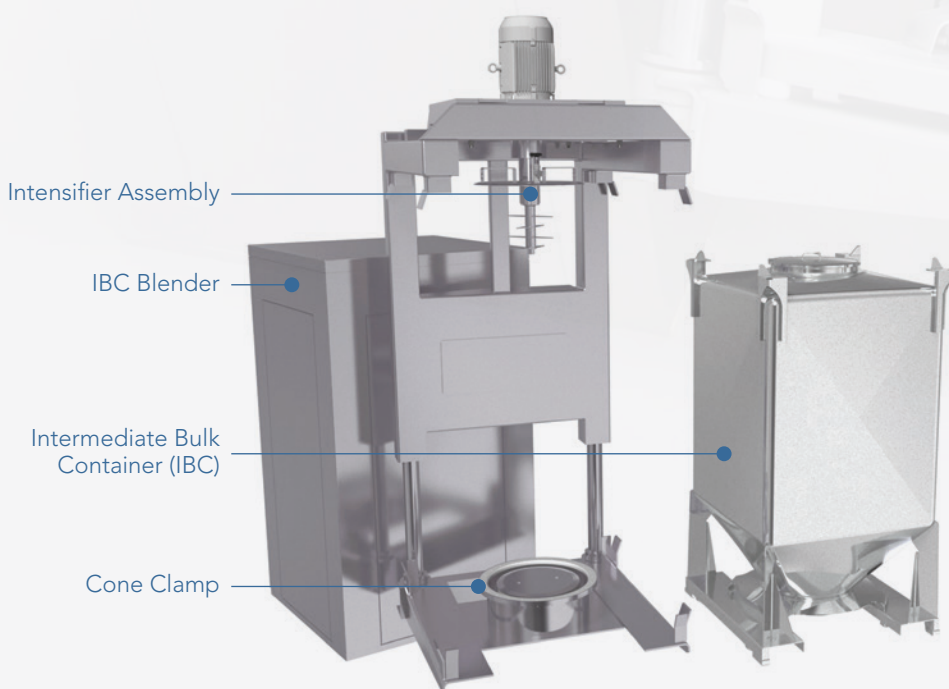

## THE MATCON BLENDING ADVANTAGE

System is always blending – filling, emptying and cleaning are done offline

In-bin blending for instant recipe changes without risk of contamination

Wide range of batch sizes give flexibility

Intensifier package expands blending capability, including liquid addition

Modular solution: factory assembled, proven design, low risk

Comes with interlocked safety cage

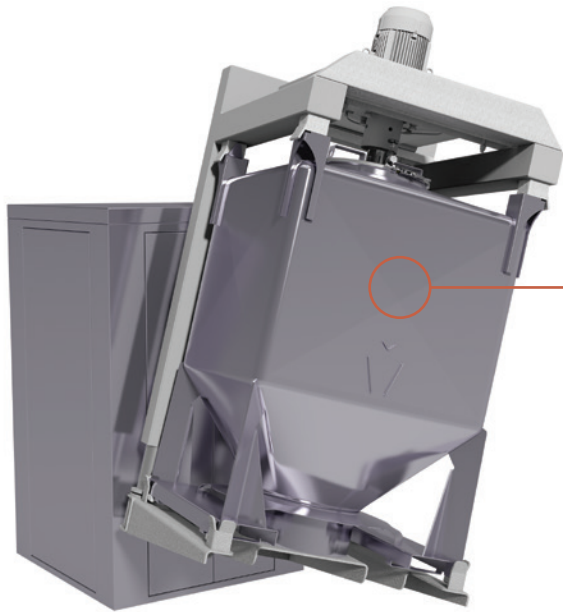

The IBC Blending module enables the mixing of any recipe, at any time.

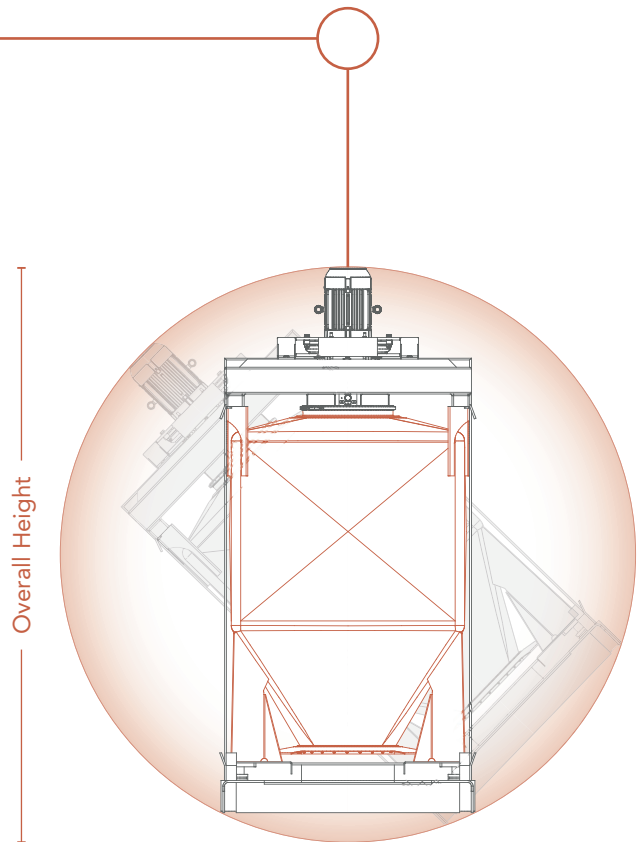

**Eliminate the time-consuming cleaning associated with traditional static mixers.**

**Rapid batch changeovers** as there is no product contact with the blender.

**No cross-contamination risk** as the IBC is the blending vessel and is fully contained.

**High OEE rates** as IBCs are formulated, emptied and cleaned offline, reducing downtime.

**Flexible batch sizes** can be blended, as one blender accommodates a multiple of different IBC sizes.

**High Shear Intensifier** extends the range of blending capabilities.

**Asymmetric tumble axis** ensures no powder hang up.

**Variable rotation speed** and mix time to suit recipe needs.

**STRUCTURE SIZES ARE DEPENDENT UPON IBC SIZE**

IBC Size	Turning Circle	Overall Height
1000	2839 mm	2912 mm
1500	3104 mm	3185 mm
2000	3373 mm	3517 mm
2500	3900 mm	4000 mm
3100	3769 mm	3938 mm

Measurements based on standard equipment

# MATCON®

POWDERS, HANDLED.

We specialise in providing complete materials handling solutions in the Food, Nutrition, Pharmaceutical and Chemical sectors.

We're not just an IBC provider, but a true partner helping you accomplish the right system for your needs.



THE POWDER HANDLING EXPERTS

[www.matconibc.com](http://www.matconibc.com)

MATCON, Bramley Drive, Vale Park West, Evesham, Worcestershire, WR11 1JH, UK  
Tel: +44 (0) 1386 769 000 Fax: +44 (0) 870 191 1116

